



ASSEMBLY INSTRUCTIONS



Item No: Table

Thank you for purchasing this quality product.

PARTS LIST:

No.	Description	Sketch	Quantity
1	Leg front and back A		1PC
2	Leg right and left B		1PC
3	Table top C		1PC

HARDWARE LIST:

No.	Description	Sketch	Size	Quantity
1	Bolt 1		M6*20	5PCS
2	Flat Washer 2		Ø6*16	5PCS
3	Hexagon key 3		4mm	1PC

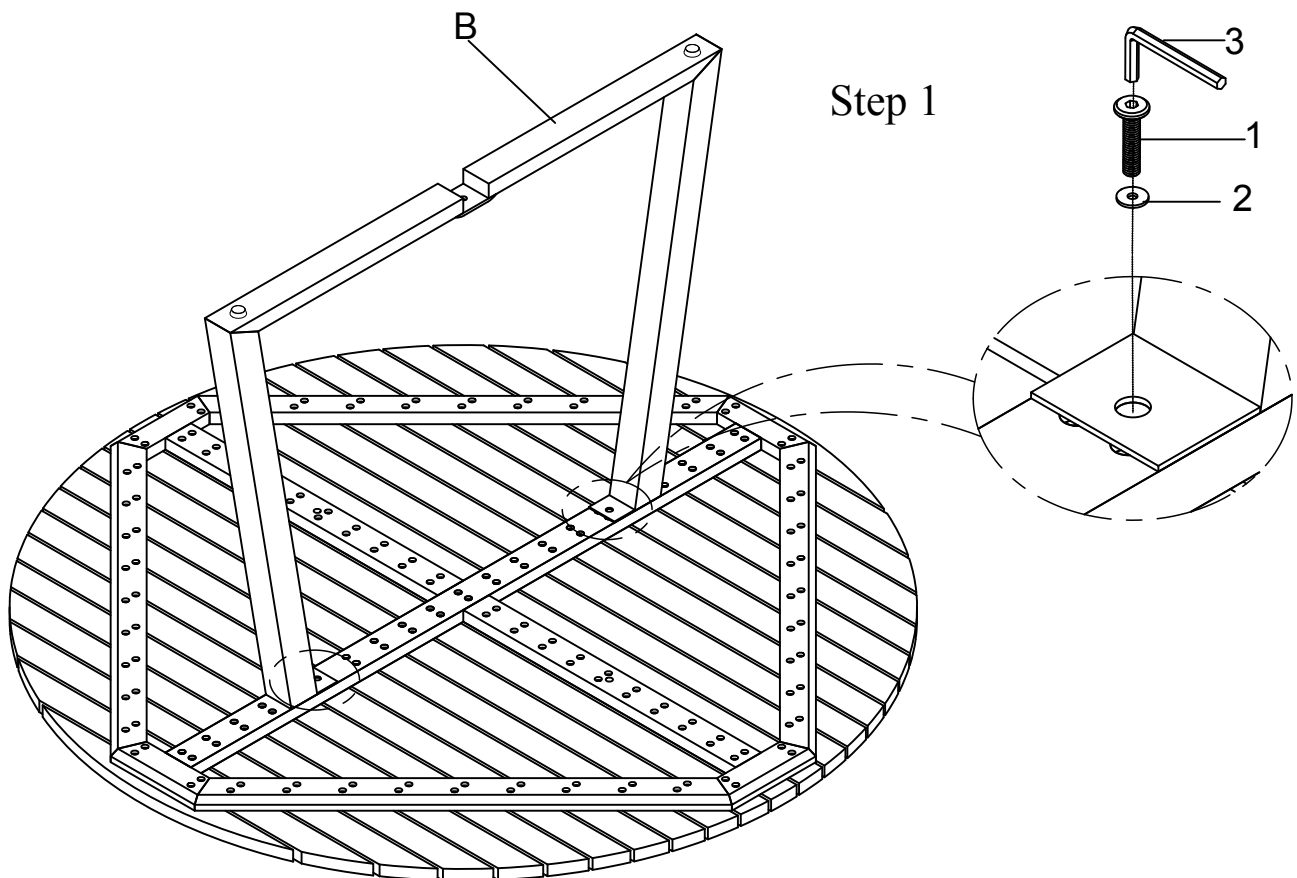

ASSEMBLY INSTRUCTIONS
Item No: Table

